

Operating manual

Kathrein Satellite Receiver UFD 345



Order No.: 260 411

KATHREIN

Antennen · Electronic

Contents

Controls, displays and connections	3
View of front panel with infrared sensor, rear panel and remote control handset	3
Front panel and infrared sensor	4
Rear panel connections	4
Remote control handset keys	4
Safety instructions	5
Important notes regarding operation	5
Important notes on siting and installation	6
Connecting up and putting into operation	7
Installing the receiver	7
Infrared sensor	7
Connecting up the unit	7
Inserting batteries into remote control	9
Receiver operation	10
Switching the unit on	10
Switchover between TV and radio mode.....	10
Selecting a programme	10
Adjusting volume, balance and tone	11
Muting the sound.....	11
Stereo-/Mono- Channel changeover	12
Video recorder playback (VCR)	12
SAT/TV changeover.....	12
Operating the receiver without remote control.....	12
Swapping, sorting and inserting programmes	12
Displaying the Info menu and programme overview.....	13
Picture optimisation when reception is weak.....	14
Programming TV programmes	15
Tuning in TV programmes	15
The "Video" menu	15
Decoder menu	17
Programme name	17
The "Audio" menu	18
Programming radio programmes	19
Tuning in radio programmes.....	19
The "Radio" menu	19
Initial settings	20
Calling the initial setup menu.....	20
OSD language	21
LNB supply voltage	21
LNB supply voltage in standby	21
Programme selection	21
On Screen Displays (OSD).....	21
Oscillator frequency	22
DiSEqC menu	23
22 kHz signal	24
Tone burst and DiSEqC signal.....	24
Switching over remote control's command set	25
Features	26
Specifications	27
Menu structure	29
Connection examples / Service note	32
Drilling template	33

Controls, displays and connections

This section contains a brief description of all the control elements, displays and connections. The key symbols presented here are also used when describing the operating sequences.

View of front panel

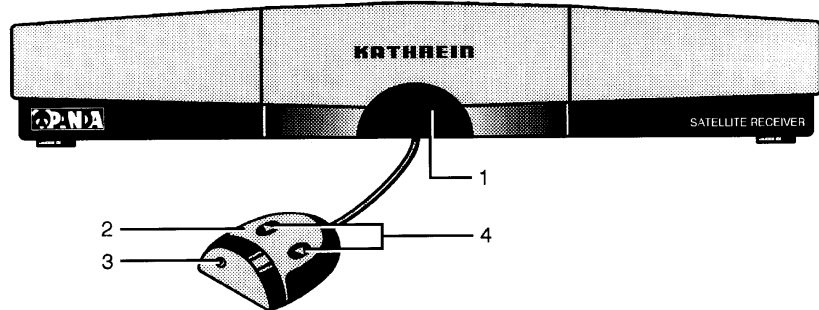

View of rear panel

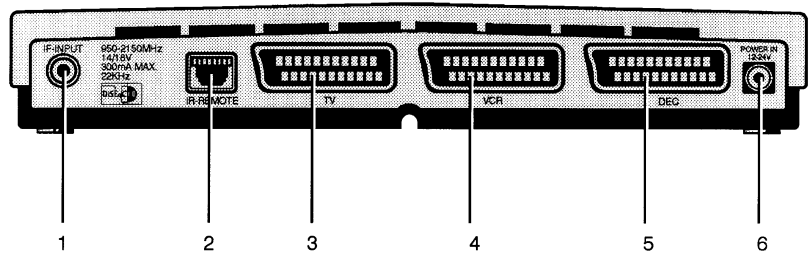

Remote control handset



Controls, displays and connections

Front panel

- 1 **Location slot for infrared sensor**
- 2 **Detachable infrared sensor**
Receiver for infrared signals from the remote control. The detachable infrared sensor allows the receiver to be installed hidden from view. All that is necessary is for the infrared sensor to be within the reception area of the infrared signals from the remote control.
- 3 **On/Off indicator (red LED)**
In standby the indicator goes out
- 4 **Programme selection keys**
Step-by-step programme selection (upwards and downwards).
Switch-on from standby by pressing both buttons simultaneously.
Switchover from TV- to radio mode by pressing both buttons simultaneously. .

Remote control handset keys



Function 1:
On/Off (Standby),
Attention: no mains isolation results!
Function 2:
Resetting from setup menu into normal operation



Numeric keys 0 - 9 for programme selection and frequency entries

to



Function 1:
Volume control
Function 2:
Selection of individual menu entries in setup mode



Function 1:
Calls up the Info menu
Function 2:
Calls up menu for "Programme slot swapping, insertion and copying"
(with **STORE** in succession)



Function 1:
Mutes the sound
Function 2:
Calls up menu for audio settings
(with **STORE** in succession)



Unassigned



Function 1:
Selects TV/SAT mode
Function 2:
Calls up menu for video settings
(with **STORE** in succession)

Rear panel connections

- 1 **Satellite IF signal input and output of LNB supply voltage**
- 2 **Connecting socket for infrared sensor (Western 8-way)**
- 3 **Scart socket, TV connection**
- 4 **Scart socket, VCR connection**
- 5 **Scart socket, decoder connection**
- 6 **Connecting socket for voltage supply 12 ... 24 V DC**



Key to call up picture optimisation menu if reception is poor



Function 1:
Command set changeover
Function 2:
Blanking of video signal (in setup mode)



Function 1:
Switchover to radio mode
Function 2:
Calls up menu for radio settings
(with **STORE** in succession)



Function 1:
Steps through programmes either up or down
Function 2:
Changing data in setup mode



Function 1:
Saves the chosen settings
Function 2:
Primary key for calling the separate setup menus (e.g. video settings)



Stereo/Mono- (2 channel) changeover

Safety instructions

The following section contains important information relating to operation, place of installation and connecting-up of the receiver. Read these notes carefully before putting the unit into operation.

Important notes regarding operation



Extended absence/Thunderstorms

During periods of extended absence or at the onset of thunderstorms always disconnect the unit from the supply, or withdraw the mains plug if the power supply unit is used. This also applies to any other equipment attached.

Mains lead

Make certain that the mains lead (power supply lead) is undamaged. Never put the unit into operation if the mains lead is damaged.

Cleaning

Withdraw the PSU mains plug before cleaning the unit. Use a dry cloth for cleaning.

Children-at-play



Pay attention that children do not insert objects into the ventilation slots. There is a risk of mortal danger due to electric shock.

Repairs



On no account remove the housing cover since there are dangerous voltages inside the unit that may be contacted. The unit must only be opened by qualified specialists, so allow them to carry out any repairs or adjustments to your receiver. Unauthorised opening entails loss of guarantee.

The electrical safety of the unit can be affected by improper tampering with it

The manufacturer's liability excludes accidents occurring to the user when the unit is opened.

Safety instructions

Important notes for siting and installation

Place of installation

Every electronic device generates some heat. The rise in temperature, however, lies within safe limits. Nevertheless, this does not rule out the possibility of slight colour changes to sensitive furniture surfaces and veneers over time due to the constant effect of heat.

In conjunction with treated furniture surfaces, the unit's rubber feet can likewise give rise to changes in colour. Where necessary, place the unit on a suitable pad.

Ventilation

The heat that is generated in this unit is dissipated quite adequately. Never install the receiver in a cabinet, shelf or rack with inadequate ventilation. Never close-off the openings on the unit that are intended for heat dissipation.

Do not place objects on top of the unit. Maintain a clearance of at least 10 cm above the unit so that the heat generated within the unit is convected away without obstruction.

Mains voltage

Run the receiver only from a 12 –24V d.c. voltage supply or from 230 V / 50 Hz when using the mains pack supplied.

The unit is not to be connected to the mains until after all the installation work has been completed.

Humidity

Protect the unit against humidity, drips and splashes.

Solar radiation/heat

Do not place the receiver close to radiators nor expose it to direct sunlight.

LNB supply voltage

If the feeder system (LNB) is supplied with an external supply voltage and the LNB supply voltage is not used for polarity switchover (e.g. Kathrein single-cable feeder system UAS 330), the receiver's LNB supply must be set to "OFF" (refer to section: "Initial settings, LNB supply voltage").

There is a risk that the receiver may suffer damage if the change-over is not carried out.

Connecting up and putting into operation

A sample configuration is to be found in section: "Connection example".

Attention!

Do not connect the unit to the mains supply until after the installation work has been carried out properly..

Please take note of guidance in section: "Safety- and Installation Instructions"

Installing the receiver

The UFD 345 satellite receiver is suitable for mobile use in motor homes or caravans, but can also serve as a fixed station in the home.

Place of installation

The modern, elegant design of the receiver with its modest dimensions means it can be placed in visual range, on top of the TV set, for example. In this case, insert the infrared sensor into the locating slot on the front of the receiver and run the cable to the rear via the cable channel on the bottom of the receiver (see below). Connect the Western plug to the Western socket (2).

Due to its modest dimensions, however, the receiver can also be placed concealed from view behind the TV set. Alternatively, the receiver can be mounted on the wall. For this, there is a drilling template for the required drill holes at the end of the guide. Cut the template out if required. In this case, the infrared sensor is sited separately.

Infrared sensor

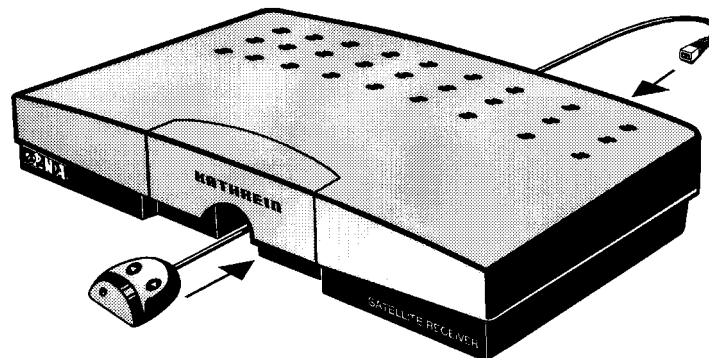

The detachable infrared sensor receives the signals from the remote control and passes them on to the receiver via the cable. As a result, it allows the sensor and receiver to be sited separately. Consequently, the receiver can be sited outside the reception range (line of sight) of the remote control, thus saving on space.

Connection of the sensor to the receiver is via the 8-way Western plug, which you should connect to the Western socket (2) on the rear of the receiver.

For optimum working, the infrared sensor should be sited at a clearly visible spot near the TV set

Connecting up the unit

Power supply

With mobile use, the receiver should be connected directly to the vehicle's on-board supply (12 ... 24 V) using the adaptor cable included (adaptor cable with universal plug for cigarette lighter or vehicle socket outlet and inner hollow conductor plug).

Connecting up and putting into operation

Connect inner hollow conductor plug to the power supply socket (6).

Caution!

If the power supply cable is modified or a different one is used, it is essential to check for correct polarity. Incorrect polarity will result in damage to the receiver.

For fixed applications use the accompanying power supply unit 230 V~/16 V=.

Satellite signal connection

- Connect the Sat IF input of the receiver to the satellite receiving system.
- For the connection use a coaxial cable with an F-type connecting plug.

If the F connector is not yet fitted to the cable:

- Insulate the cable as indicated in the following illustration, and
- Carefully screw the F connector onto the cable end until it is firmly seated on the cable.

Attention!

Do not use any tools to screw the F plug onto the cable or to tighten to the F socket. Put the connectors on hand-tight only.

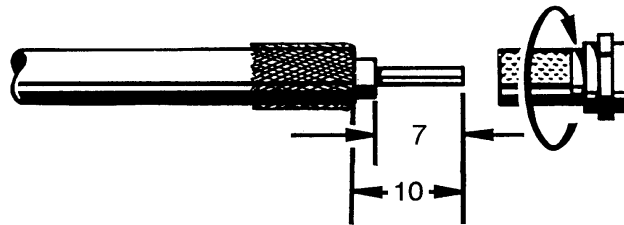

Attention!

When fitting the plug, make certain that none of the fine wires of the braided shield makes contact with the inner conductor giving rise to a short-circuit.

Receiving system presets

Presetting carried out for the control signals was for conventional receiving systems, thus 14/18 V for polarity switching and 22 kHz switching signal for satellite selection in the case of multifeed receiving systems.

If DiSEqC or tone-burst switching matrices are to be used in the receiving system, the setting must be selected for "DiSEqC" signal or "Tone Burst" in the initial setup menu at submenu "DiSEqC".

For this, refer to section: "Initial settings, DiSEqC menu".

Also take note of the technical guide for the matrices.

Connecting up and putting into operation

TV and video recorder connection (VCR)

- Connect-up the satellite receiver (TV Scart socket) and TV set with a Scart cable.

If your TV set has stereo capability, a Scart connection allows you to receive the sound in stereo.

- Connect-up the video recorder and satellite receiver (VCR Scart socket) again using a Scart cable.

Decoder connection

You can also connect-up a decoder to the receiver for Pay-TV programmes.

No further setting is necessary for decoders that require a video signal and supply a switching signal, such as Premiere decoder and Videocrypt decoder, for example..

Important

With decoders that do not supply a switching voltage, the receiver must be programmed appropriately beforehand (see "The video menu" section in chapter "Programming TV programmes").

Also take note of the decoder specification!

- Using a Scart cable connect-up the decoder to the decoder Scart socket.

Inserting batteries into remote control handset

- Remove the cover on the rear of the remote control handset.
- Insert both of the batteries supplied into the remote control handset. Make certain that the batteries are inserted with the correct polarity!
- Replace the cover again.

Note

Exhausted batteries are special waste and should not be disposed of with household refuse. Instead, hand them in to a collection centre for used batteries!

Receiver operation

In this chapter you learn how to select TV and radio programmes using your receiver, and how to adjust the volume and set up other functions.

Switching the unit on

- Once the supply voltage is connected the unit goes into standby mode.
- The  key on the remote control is used to switch between standby and normal operation. Operation is shown by means of a red LED indicator in the infrared sensor.
- The last programme slot selected is tuned in (last-status memory).

Switching between TV and radio mode

Your receiver allows you to receive TV programmes or radio programmes.

After switching on, the receiver is in either the TV mode or the radio mode (depending on the mode when switched off.).



In TV mode, the programme slot indicator in the on-screen display (OSD) begins with "P". In radio mode, the screen is blanked out and the on-screen display begins with "R..".

- Press the  key on the remote control handset to switch between TV- and radio mode.

Note

In the initial setup menu, a continuous on-screen display of the radio programme slot can be selected independent of the TV setting (see section: "Initial settings, On Screen Displays").

Selecting a programme



- Use the numeric keys ... to select the desired programme directly.

Example for a three-digit entry (with setting "free programme selection"):

Selection of programme slot 147

- 1 is entered, programme slot 1 appears
- 4 is entered, programme slot 14 appears
- 7 is entered, programme slot 147 now appears.

or

- Use the  CH  keys to step through the programmes in succession.

After the programme changeover, the programme slot and programme name are superimposed on the screen for approximately three seconds.

Receiver operation



Note

With the setting “2- or 3-digit programme selection” there is a switch to the desired programme after approximately 3 seconds. Digits can be entered during this time period.





With the setting “free programme selection”, the receiver switches to the corresponding programme slot immediately after each input. (see example above).

In the initial setup menu, a continuous on-screen display of the programme slot can be selected (see section: “Initial settings, On Screen Displays”).

Adjusting volume, balance and tone

- If you press one of the   keys the following menu appears for adjustment of the volume, balance, tone (treble and bass), stereo-width and pseudo-stereo:

>Volume	21
	
Balance	00
Treble	00
Bass	00
Stereo width:	00
Pseudo-Stereo:	OFF

With the  CH  keys or the  key you can select the respective menu entry and then makes changes with the  CH  keys.

The settings are not operative at the VCR Scart socket in order not to disturb video recordings.

The on-screen display is removed again after approximately 3 seconds.

Note

In the menu entry “Stereo Width” the stereo base width can be adjusted independently.

“Pseudo-Stereo” can be used to simulate a “stereo-like” effect with mono programmes, and should thus only be activated with mono reception.

The “pseudo-stereo” effect can be simulated if a stereo programme is switched to mono.

Muting the sound

- Press the  key.

The sound is muted, allowing you to make a phone call undisturbed, for example.

- Press the  key again to turn the sound back on.

Note

Mute is not operative at the VCR Scart socket.

Receiver operation

Stereo- / Mono- / Channel changeover

Broadcasts can be transmitted in the two-tone channel method (e.g. original tone "English" on channel 1, "German" tone on channel 2).

- Press the  key. Each time you press the key, you switch the sound channel in the order:
Stereo → Channel 1 → Channel 2 → Stereo
- The selected channel is shown on the screen.

The setting is not saved. After a change in programme the programmed setting takes effect again.

Video recorder playback (VCR)

For playback from the video recorder, the satellite receiver needs to be switched on to ensure the signal path is switched through from the VCR Scart socket to the TV Scart socket.

SAT/TV changeover

Where the satellite receiver and TV set are connected via a Scart cable, many TV sets immediately switchover signal input to video reception (on the Scart socket) when the satellite receiver is turned on. The switching voltage of the TV Scart socket therefore needs to be switched off if you want to view a terrestrially broadcast TV programme.



- Press the  key.

The switching voltage on pin 8 of the TV Scart socket is turned off, and it is turned on again by pressing once more.

In Sat mode, "Sat mode" is displayed on the screen for approximately 3 seconds.

Operating the receiver without remote control

On connecting the satellite receiver to the supply, the unit always reverts to the last operating mode it was in prior to being switched off.

If the unit was disconnected from the supply whilst in standby mode, it reverts to standby mode on reconnection to the supply. If you happen to have mislaid the remote control handset, you can switch the receiver on by simultaneously pressing both   keys on the infrared sensor.

You can switch between the "TV" and "Radio" operating modes in the same manner.

Swapping, sorting and copying programmes

With the function: "Swapping, sorting (inserting) and copying programmes" you can adapt the programme order to suit your individual requirements..

- If you want to alter the current programme order, you can do this with the functions:
 - Swap programme slots or
 - Insert programme slot (sort) or
 - Copy programme slot.

Receiver operation

Example

You want to insert the programme from programme slot "P083" into programme slot "P003"

- Select programme slot P083 using the **0**...**9** keys or the **CH** keys.
- Press the **STORE** + **i** keys in succession.

The menu for the function "Swap programme slots" appears.

- Press the **i** key once again.

The screen display for the "Insert" function now appears:

Insert	
Current Programme:	Insert at:
P083	P003
RAI 3	SAT 1
▲▼ 0-9	STOR STBY INFO

- Select programme slot P003 using the **0**...**9** keys or the **CH** keys.
- Press the **STORE** key twice.

The programme from programme slot 83 is now inserted at programme slot 3.

The following message appears on the screen:

Please wait

Following message appears when exchange completed:

Programme inserted!

- To switch to the "Copy" mode press the **i** key once again.
- Exit from the menu with **power**.

Displaying the Info menu and programme overview

Displaying Info

The unit is in normal mode of operation (TV- or radio mode)

- Press the **i** key.

The Info menu appears with instructions for calling the setup menus for initial-, video- and audio settings and the programme list in TV mode, plus instructions for calling the setup menus for initial settings and radio settings in radio mode.

Receiver operation







Programme overview

(in TV mode only)

- Press the  key once again:

The programme overview appears on the screen.

The programme currently selected is indicated by <..>.

- The  keys can be used to single-step through the programme list while the  keys allow you to page through in steps of 10.
- Pressing the  key once results in switchover to the marked programme. On exiting the programme overview with  key there is a switch back to the previous programme.
- Pressing the  key twice results in switchover to the marked programme and exit from the programme overview.
- To exit from the menu without selecting a programme press key .

Picture optimisation when reception is weak

Where weak reception results in a grainy picture as, for example, at the fringes of the reception area, the "Picture optimisation" function can be used to achieve an improvement.

- Press the  key. The following on-screen display appears:



With the  keys you can now carry out picture optimisation.

Note

The power radiated by individual transponders (satellite programmes) varies. Besides this, the footprints of the transponders are also different. Picture optimisation must therefore be carried out for each programme and is not stored either. This means that picture optimisation must be carried out again after changing the programme.

Programming TV programmes

The satellite receiver has already been factory pre-programmed for satellite receiving systems with feed systems (receiving system) which have an oscillator frequency of 9.75 GHz. All of the programmes set up are listed in the table enclosed.

If your satellite receiving system uses a feed system with a different oscillator frequency, the receiver only needs to be matched to the feed system oscillator frequency during the installation.

The procedure for this can be found in section: "Initial settings, Oscillator frequency".

Tuning in TV programmes



To tune in to new TV programmes, the video and audio reception parameters need to be set up accordingly.

The latest programme assignments can be obtained from satellite programme magazines, or called up via the videotext of programme Sat 1 from page 516.

- First select the programme slot that you want to programme afresh.
- Call up the video menu by pressing the **STORE** + **TV/SAT VIDEO** keys in succession.



or

- Call up the audio menu: press keys **STORE** + **MUTE AUDIO** in succession.
- Switch between video and audio menus using the **MUTE AUDIO** key or the **TV/SAT VIDEO** key.

- Select the desired menu line using the keys  .

- For direct numeric input use the keys **0**...**9**.

or

- Alter the values step-by-step using the  **CH**  keys.
- Press the **STORE** key twice in order to save your settings.
- Exit from the menu with the  key.

Note

You can terminate any setup procedure immediately (also without saving settings) by returning to normal operation with the  key.

The "Video" menu

The following settings can be made in the video menu:

Programme slot:	P002
Programme name:	ZDF
Sat-Frequency:	10964 MHz
Polarisation:	Hor. Low
Orbit Position:	1
Deviation:	16 MHz
Oscillator:	LO 1
Decoder menu...	STOR
▼▲ VOL 0-9 VID AUD A/B STBY	

The bottom line shows the keys you can use to make the settings.

Programming TV programmes

Satellite frequency

With input via the numeric keys **0**...**9** frequency input is in 5-figure form in the range **10700** to **12747** MHz. With the **CH** keys you can attain the optimum receiving frequency by moving in 1 MHz steps (recommended if the picture is grainy due to weak signals).

Polarisation/Orbit position

In these two menu entries, signal selection is carried out by the LNB supply voltage and the 22 kHz switching signal, which is superimposed on the LNB supply voltage.

Polarisation

In the "Polarisation" menu entry, the voltage level is used (14 or 18V) to set the polarity (vertical or horizontal) and the 22 kHz switching signal to select the frequency range (see table).

Frequency range	Polarisation	LNB voltage	Switching signal, 22 kHz	Setting
10.7-11.7 GHz	vertical	14 V	Off	Vert. Low
	horizontal	18 V	Off	Hor. Low

Orbit position

In the "Orbit Position" menu entry, the 22 kHz switching signal is used to switch between two (or more) satellites for multifeed receiving systems (see following table).

Satellite	Orbit position	22 kHz switching signal
Astra 19.2° east	1	Off
Eutelsat 13° east	2	On
Eutelsat 10° east	3	Off
Eutelsat 16° east	4	On

In the initial setup menu (submenu "DiSEqC"), setting is carried out for the menu entry the 22 kHz switching signal is operative for (polarisation or orbit position).

Note

With Astra satellites, only digital signals are transmitted in the upper frequency band (high-band). Special receivers are also required, however (DVB receiver; d-Box).

The customary (analogue) signals are transmitted on the lower frequency band (low-band). The same is also true at the moment for Eutelsat programmes.

- Select the required polarity therefore as either Vert. Low or Hor. Low only.

In the factory presetting (as delivered), the setting "Pos. A/B" has been chosen in the "DiSEqC" initial setup menu, menu entry "22 kHz signal".

The settings Vert. High and Hor. High are not operative.

Video deviation

The satellites transmit their signals with different video deviation, 16 or 25 MHz. The setting has an effect on the picture brightness.

- Adjust the video deviation to obtain optimum picture brightness.

Oscillator

The receiver is equipped with four LO frequency groups (LO 1 to LO 4), which can be set to give troublefree matching to different feed systems with different oscillator frequencies (e.g. Telecom 1A).

In the delivered state, all four oscillator frequencies are set to 9.75 GHz

Programming TV programmes

(9750 MHz).

The LO frequency groups are also used for satellite recognition during fully automatic adjustment with our HDP 150 automatic positioner.

For this the individual satellites are assigned the following LO groups:

Satellite	LO group
Astra	LO 1
Eutelsat 13°	LO 2
Eutelsat 10°	LO 3
Eutelsat 16°	LO 4

To change the LO frequencies refer to the initial setup menu.

Decoder menu

You can attach a decoder to the decoder Scart socket for a Pay-TV programme.

The receiver recognises Pay-TV programmes for which decoders supply a switching signal (e.g. like Premiere) independently, and switches this signal through to the TV- and VCR Scart socket.

For decoders that do not supply a switching voltage the following setting is to be carried out.

- Call up the video setup menu,
- Select menu entry "Decoder menu",
- Activate the "Decoder menu".,
- Set the video signal path to external,
- Set the audio signal path to external only if audio signal is encoded as well.



Note

If the decoder connected requires a baseband signal with PAL- or MAC-de-emphasis, a setting of baseband PAL or baseband MAC needs to be made in menu entry "Signal type" (take note of decoder specification).

- Save the settings with the **STORE** key (press twice).

Programme name

In the "Programme name" line, you can enter a 5-character station identifier of your choice.

- Using the  key select the menu entry: "Programme name".
- Using the  **CH**  keys select the first character.
- with the **STORE** key move on to the next character..
- Select the remaining characters in the same way.
- Change to the "Audio menu" with the **MUTE AUDIO** key.

or

- Press the  key to return to reception mode.

Programming TV programmes

The "Audio" menu

The following settings can be made in the audio menu:

	P002
	ZDF
TV sound	
Mode:	Stereo
Frequency:	▶ 7.02/7.20 MHz
De-emphasis:	DNR/75µs
▼▲ VOL 0-9 VID A/B STOR STBY	

Audio mode

Setting of operating mode as: "Stereo", "Mono narrow" or "Mono wide"

Operating mode "Stereo" and "Mono narrow" is selected on reception of the sound sub-carrier, "Mono wide" is selected on reception of the sound main carrier.

Audio frequency

Input of the audio frequency via the numeric keys **0**...**9** is in 3-digit form in the range 5.00 to 8.80 MHz. In stereo mode, the frequency is to be entered for the left sound channel. The frequency for the right sound channel then automatically lies 180 kHz above the left sound frequency.

The following is a list of fixed, pre-programmed audio frequencies that can be selected using the **CH** keys.

Mode	Sound carrier frequencies	Mode	Sound carrier frequencies
Stereo	7.02 / 7.20 MHz	Mono (narrow) MNR	7.02 MHz
	7.38 / 7.56 MHz		7.20 MHz
	7.74 / 7.92 MHz		7.38 MHz
	8.10 / 8.28 MHz		7.56 MHz
Mono (wide) MWD	5.80 MHz		7.74 MHz
	6.50 MHz		7.92 MHz
	6.60 MHz		8.10 MHz
	6.65 MHz		8.28 MHz
	6.80 MHz		

Audio de-emphasis (for sound type " Mono wide" only)

Set the de-emphasis for the best sound impression to 50 µs or J17.

In the "Stereo" and "Mono narrow" audio modes, the de-emphasis "dnr" with "75 µs" is selected automatically.

Stereo, Mono narrow: dnr, 75 µs
Mono wide: 50 µs or J17

- Save the settings with the **STORE** key (press twice).

If you want to make new settings for further programme slots:

- Change over to the "Video menu" with the **TV/SAT VIDEO** key.
- Move to the first menu line, "Programme slot", and select the next programme slot.
- Select further programme slots in the same manner.
- To exit the setup menu press the **Power** key.

Initial settings

Programme providers are continually bringing out new radio programmes for broadcast via the satellites. The “Radio” menu allows you to store these programmes.

The settings for radio programmes in “Radio” mode are carried out in the same way as for the “TV” mode.

Tuning in radio programmes

- Switch from “TV mode” into “Radio mode” using the **RADIO** key.
 - First select the programme slot that is to be programmed afresh.
 - Call up the radio menu by pressing the **STORE** + **RADIO** keys in succession.
 - Select the desired menu line using the **◀▶** keys.
 - For direct numeric input use the keys **0...9**
- or
- Alter the values step-by-step with the **▼CH▲** keys.
 - Press the **STORE** key twice in order to save your settings.
 - Exit from the menu with the **⏻** key.

The “radio” menu

The following settings can be made in the radio menu:

Radio programme:	R 02
Sat frequency:	▶ 11214 MHz
Polarisation:	Hor. Low
Orbit position:	1
Deviation:	16 MHz
Oscillator:	LO 1
Mode:	STEREO
Frequency:	7.38/7.56 MHz
De-emphasis:	DNR/75µs
▼▲ VOL 0-9 A/B STOR STBY	

The bottom line shows the keys you can use to make the settings.

Radio programmes are transmitted on sound subcarriers only. The setting to be made is therefore either “Stereo” or “Mono narrow”. Here the audio de-emphasis is selected automatically as “DNR” and 75 µs.

Note

You can terminate any setup procedure immediately (also without storing) by returning to normal operation via the **⏻** key. Grundeinstellungen

In the initial setup menu, matching of the satellite receiver to the satellite receiving system is carried out.

Important

The receiver has already been factory pre-programmed for standard satellite receiving systems.

Alterations to the initial setting are therefore necessary only if your receiving system deviates from this type of installation or if you happen to want different settings.





The settings in the initial setup menu are generally carried out by the specialist dealer on installation of the satellite receiving system.

To prevent any unintentional alterations in the initial settings, the initial setup menu

Initial settings

can be invoked only from the switched-off state. (power supply interrupted).

Calling the initial setup menu





- Withdraw the mains supply plug (inner hollow conductor plug) from the socket (6).
- Press both the programme selection buttons (4)   on the infrared sensor and keep them pressed.
- Insert the unit's mains supply plug again.
- When the following screen menu appears release the keys  .

The initial setup menu is displayed.

>OSD language:	▶	ENGLISH
LNB supply:		ON
-in standby:		OFF
Programme selection:		FREE
OSD:		OFF
Oscillator menu...		
DiSEqC menu ...		
▼▲ VOL 0-9 A/B STOR STBY		

The bottom line shows the keys you can use to make the settings.

Settings are made in the initial setup menu in the same manner as in the other menus for the station programming:

- Select menu entries with the   keys.
- Carry out settings and call up submenus with the   keys (and use numeric keys 0-9 on inputting frequency).
- Press the **STORE** key twice to save your settings.
- Return with the  key.

Initial settings

OSD language

Here you can select the language for the on-screen displays. The choice available comprises: German and English and French.

Default: **German**

LNB supply voltage

Here you can turn off the power supply for the feed system if this is implemented by an external power supply and signal selection is likewise not carried out by means of the LNB supply voltage (e.g. Kathrein single-cable feed system UAS 330).

Default: **ON**

LNB supply voltage in standby

When the receiver is in standby the LNB supply voltage is normally switched off. If terrestrial signals and satellite signals are combined in the receiving system, and the power supply for the relevant components comes from the receiver, the power supply must also be guaranteed when the receiver is in standby. In this case switch the power supply in standby to **"On"**.

Default: **"Off"**.

Programme selection

You have the option of entering the programme number in one-, two-, or three-digit form or in "free" form (Default: "free").

Setting	Settable programme slots
One-digit input	Programme slots 1 to 9
Two-digit input	Programme slots 1 to 99
Three-digit input	Programme slots 1 to 200
Free input	Programme slots 1 to 200

On Screen Displays (OSD)

Here you can select whether the programme slot and programme name are to be displayed continuously, or whether they are to be removed again approximately three seconds after programme changeover..

This setting can be made differently in TV mode and radio mode.

Default: TV mode **"Off"**.
 Radio mode **"On"**.

To call the initial setup menu for radio, the receiver must be switched into radio mode before being switched off. Then call the initial setup menu in the usual way.

Initial settings

Oscillator frequency

The satellites radiate their programmes in a frequency range that satellite receivers are unable to process. In the receiving system (known as the **LNB** - Low Noise Block converter or **LNC** - Low Noise Converter) this frequency is converted into a lower frequency that can be processed by satellite receivers.

The satellite transmission frequencies lie in the following ranges:

10700 ... 11700 MHz	Low-band
11700 ... 12750 MHz	High-band

The receiver's input frequency range, however, lies in the range: 920...2150 MHz.

Conversion of the higher frequencies into a lower frequency is achieved with the aid of the oscillator frequency (LO frequency). Various oscillator frequencies are used for the conversion according to the satellite frequency range and type of system.

For Astra and Eutelsat receiving systems, this is generally 9.75 GHz (9750 MHz) for the lower frequency band (low-band) and 10.6 GHz (10600 MHz) for the upper frequency band (high-band). Older receiving systems still operate in the low-band region with 10 GHz oscillator frequency.





The receiver calculates the frequency onto which it needs to tune by subtracting the oscillator frequency from the satellite transmission frequency stored for each programme.



As a result, you can easily install the UFD 345 on other receiving systems without needing to reprogramme every single programme slot.

You only need to set up the particular oscillator frequencies that your receiving system uses.

In the delivered state, the oscillator frequency is set to 9.75 GHz (9750 MHz) for all of the LO groups (LO 1 to LO 4).

Changing the oscillator frequency

- Call the initial setup menu (see paragraph: "Calling the initial setup menu").
- Using the   keys move to menu entry "Oscillator menu . . .".
- Call up the "Oscillator selection" submenu using the  **CH**  keys.
- Move to line in which you want to alter the oscillator frequency (LO 1... LO 4) .
- Using the numeric keys set the desired LO frequency in 5-digit form (e.g. 09750).

The already pre-programmed LO frequencies listed below can be selected with the  **CH**  keys

09610	09665	09750	09950	10000
10230	10259	10500	10600	10700
10750	11000	11125	11300	11450

- Further oscillator frequencies are set up by the same method.
- Press the **STORE** key twice to save your settings.

Initial settings

DiSEqC menu

Fundamentals of the DiSEqC signal (Digital Satellite Equipment Control)

In order to select the satellite signals different control signals are required. Up until now, the 14/18V LNB supply voltage and the 22 kHz signal (superimposed on the LNB supply voltage) have been sufficient for signal selection for the majority of applications.

With these four control criteria it is possible to switch between horizontally and vertically polarised signals, as well as between two satellites (multifeed reception).

With the extension of the frequency range to the 12 GHz region (high-band region 11.70 – 12.75 GHz) or for reception of more than two satellites, additional control criteria are required for LNB selection and signal selection.

The “DiSEqC” control signal has been developed by Eutelsat in collaboration with Philips.





The “DiSEqC” control signal is, in fact, a special form of modulation (pulse-width modulation) of the already existing 22 kHz signal.

Here one can differentiate between:

- DiSEqC tone burst
(also termed Simple DiSEqC or just DiSEqC)
- DiSEqC 1.0
- DiSEqC 2.0

The UFD 345 receiver is equipped with both the tone-burst signal and DiSEqC 1.0. The setting required is dependent on the components of your receiving system.

Settings in the DiSEqC

- Call the initial setup menu (see paragraph “Calling the initial setup menu”).
- Using the   keys move to menu entry “DiSEqC menu . . .”.
- Activate the submenu “DiSEqC menu . . .” using the  CH  keys

The following menu appears (factory preset):

DiSEqC SETTINGS	
>22KHz-Signal:	▶ High/Low
Tone Burst:	OFF
DiSEqC:	OFF
DiSEqC Repeat:	OFF
Remote Freq.:	1000 MHz
▼▲ VOL 0-9 A/B STOR STBY	

The bottom line shows the keys you can use to make the settings.

Initial settings

22 kHz signal

In this menu entry, you specify whether the 22 kHz signal is to be used to switch between a satellite's lower and upper frequency range (low/high) or to switch between two satellite positions (Pos. A/B).

22 kHz: High/Low:	Freq. range	22 kHz
	Low	Off
	High	On

(Factory preset)

or

22 kHz: Pos A/B :	Orbit Pos.	22 kHz
	1 and 3	Off
	2 and 4	On

See also video setup menu, menu lines:

Polarisation and Orbit Position

Tone-burst and DiSEqC-signal

If more than four control criteria are needed in a receiving system, a DiSEqC control signal is required.

Which of the two setting options is required: "Tone Burst" or "DiSEqC" depends on the components of the receiving system.

Thus take into account the specifications of the components present in the receiving system (switch-over matrices).

Tone burst

In the "Tone burst" menu entry the following settings of the 22 kHz signal are possible:

Switching states on setting:

22 kHz signal → **High/Low** and
Tone burst → **Pos. A/B**:

Low High	22 kHz	Off On
Pos. 1	Tone burst	0
Pos. 2	Tone burst	1

Switching states on setting:

22 kHz signal → **Pos. A/B** and
Tone burst → **Opt. A/B**

Pos.	Tone burst	22 kHz
1	0	Off
2	0	On
3	1	Off
4	1	On

DiSEqC

The switching options are further extended with the DiSEqC signal. For an optimal setting, it is essential to know the switching criteria of the receiving system.

Initial settings

Thus take into account the specifications of the DiSEqC matrices or get in touch with the installer of the receiving system..

DiSEqC Repeat

If "DiSEqC components" are cascaded in a satellite receiving system (several DiSEqC matrices are connected in series), the menu entry "DiSEqC Repeat" must be switched to "On"

Remote

The "Remote" setting in the "DiSEqC" menu entry is intended for future applications.

If the UFD 345 receiver is operated in a receiving system with a "Subscriber-controlled preprocessing system" e.g. "Kathrein UFO mini digital", *Remote* must be set in the DiSEqC menu.

In this case, the corresponding transmission frequency is selected in menu entry "Remote Frequency" in the range 920 to 2150 MHz. The satellite signal is transmitted from the receiving system to the receiver on this frequency.

- Press the **STORE** key twice to save your settings.
- Exit from the initial setup menu with the **POWER** key (press twice).

Note

If you exit the menus without saving, the settings will be lost.

Switching over remote control's command set

The remote control handset contains two command sets. This allows two receivers of the 200/300 series to be operated independently in a room (not in conjunction with a twin receiver).

For this purpose, programme one receiver on command set 1 and the second receiver on command set 2.

- Switch on receiver 1 and switch off receiver 2 (with the mains switch on the unit or interrupt the power supply).
 - Press the **A/B** key and keep it pressed.
 - Using the numeric keys enter "001".
- Switch receiver 1 off (with the mains switch on the unit or interrupt the power supply) and switch receiver 2 on.
 - Press the **A/B** key and keep it pressed.
 - Using the numeric keys enter "002".
- Switch receiver 1 on once again.
 - Press the **A/B** key and keep it pressed.
 - Using the numeric keys enter "003".

Note

With the first two settings the remote control must be pointed towards the respective receiver which is switched on.

With the **A/B** key you can now switch between the two command sets A and B (toggle function) and operate the two receivers in alternation.

On delivery command set 1 is always active.

Note

If you are using only one receiver and the active command set has been switched over inadvertently due to maloperation rendering the receiver inoperable, the remote control can be switched back to command set 1 without difficulty. The procedure for this has already been described above.

Features

The UFD 345 receiver is equipped with the following features:

- 200-channel memory for TV programmes, freely programmable
- 99-channel memory for radio programmes, freely programmable
- Low-threshold tuner for picture optimisation when reception is poor
- Selectable oscillator frequencies allow troublefree matching to feed systems with divergent oscillator frequencies.
- Detachable infrared sensor permits concealed installation of the receiver
- Dimensions are small
- Radio button
- Stereo / Dual tone switchover
- Audio frequency range from 5.0 MHz to 8.8 MHz
- Sound muting and volume control
- Dynamic noise reduction (DNR) Wegener-Panda 1
- Stereo reception
- On-screen display (OSD) 3 languages (German, English, French)
- 22-kHz control signal, programmable
- DiSEqC 1.0 and tone-burst control signal
- LNB supply voltage can be turned off
- Runs off 12-24 VDC for mobile use
- Comes with additional power pack for mains operation
- Connecting socket for data copying function (programme data read-in and read-out with the "Copy Programmer")
- Programme swap, sort and copy functions
- Infrared remote control with command set changeover (allowing operation of two receivers in a room)
- 3 Scart sockets for TV-, VCR- and decoder connection
- Last-status memory

Specifications

General

Unit dimensions (B/H/D)	271 / 50 / 150 mm
Weight Receiver	Approx. 0.6 kg
Power pack	Approx. 0.76 kg

Temperature range

Ambient temperature	+5 °C ... 40 °C
---------------------	-----------------

Accessories

Power pack 230 V ~/ 16 V=1 A

Infrared sensor, Infrared remote control

Scart cables, 12 V connecting cable with universal plug 6-24 V DC

2x 1.5 V batteries, type: LR 03, size: AAA (micro)

Operating manual



Scart socket assignments

Signal	Pin No.	TV	VCR	Decoder
AUDIO Output Right	1	X	X	X
AUDIO Input Right	2		X	X
AUDIO Output Left	3	X	X	X
AUDIO Ground	4	X	X	X
BLUE Video Ground	5	X	X	X
AUDIO Input Left	6		X	X
BLUE Video	7			
Function Switching	8	X	X	X
GREEN Video Ground	9	X	X	X
Commn. Data Line 2	10			
GREEN Video	11			
Commn. Data Line 1	12			
RED Video Ground	13	X	X	X
Commn. Data Ground	14			
RED Video	15			
Blanking Signal	16			
VIDEO Ground	17	X	X	X
Blanking Ground	18	X	X	X
VIDEO Output	19	X	X	X
VIDEO Input	20		X	X
Common Ground	21	X	X	X

Menu structure

Video- and Audio Setup Menu

Return (stepwise) into normal programme mode with key 

Save settings with key  (press twice)

Select menu entries with 

Make the setting with  or with the numeric keys for frequency setting

Change from Video menu to Audio menu with key 

Change from Audio menu to Video menu with key 

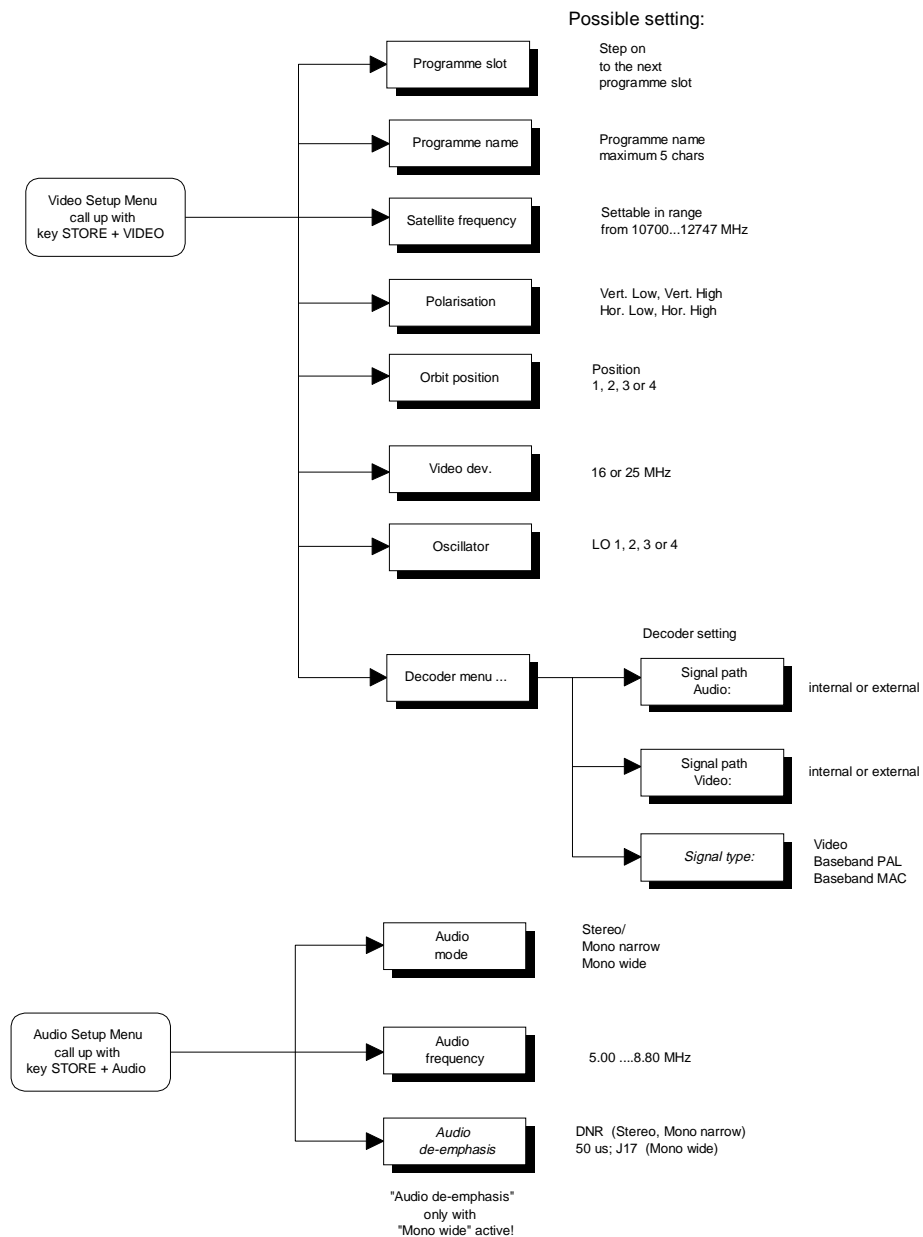



Menu structure

Radio Setup Menu

Return (stepwise) into normal programme mode with key 

Save settings with key  (press twice)

Select menu entries with  

Make the setting with   or with the numeric keys for frequency setting

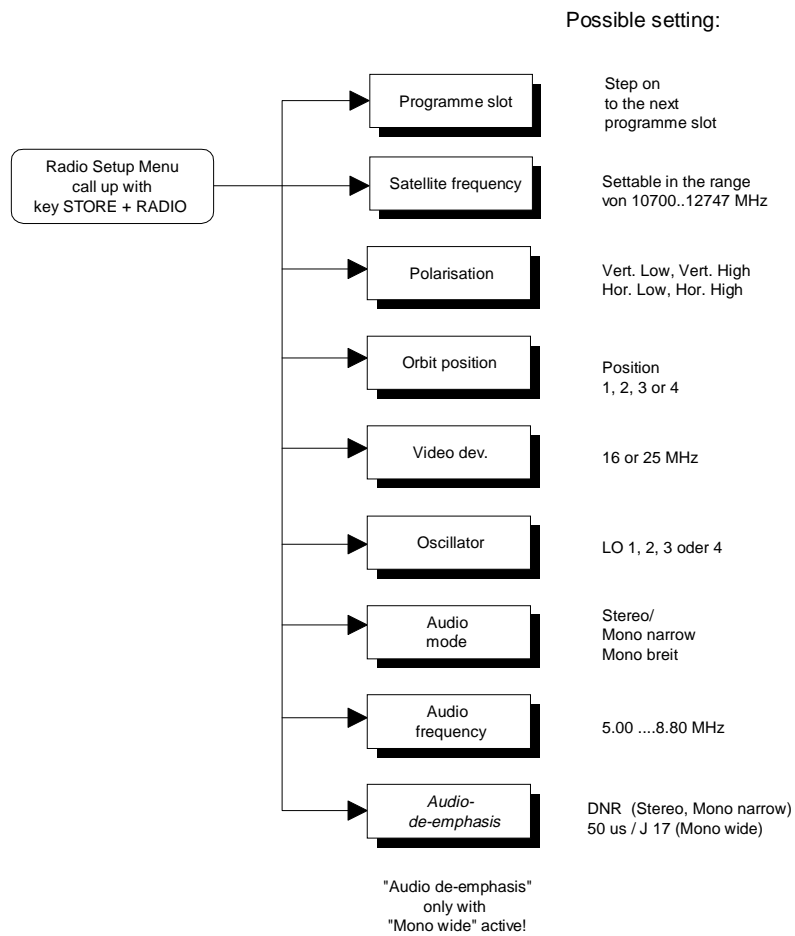

Menu structure

Initial Setup Menu

Return (stepwise) into normal programme mode with key  .

Save settings with key S  (press twice).

Select menu entries with   .

Make the setting with  CH  or with the numeric keys for frequency setting .

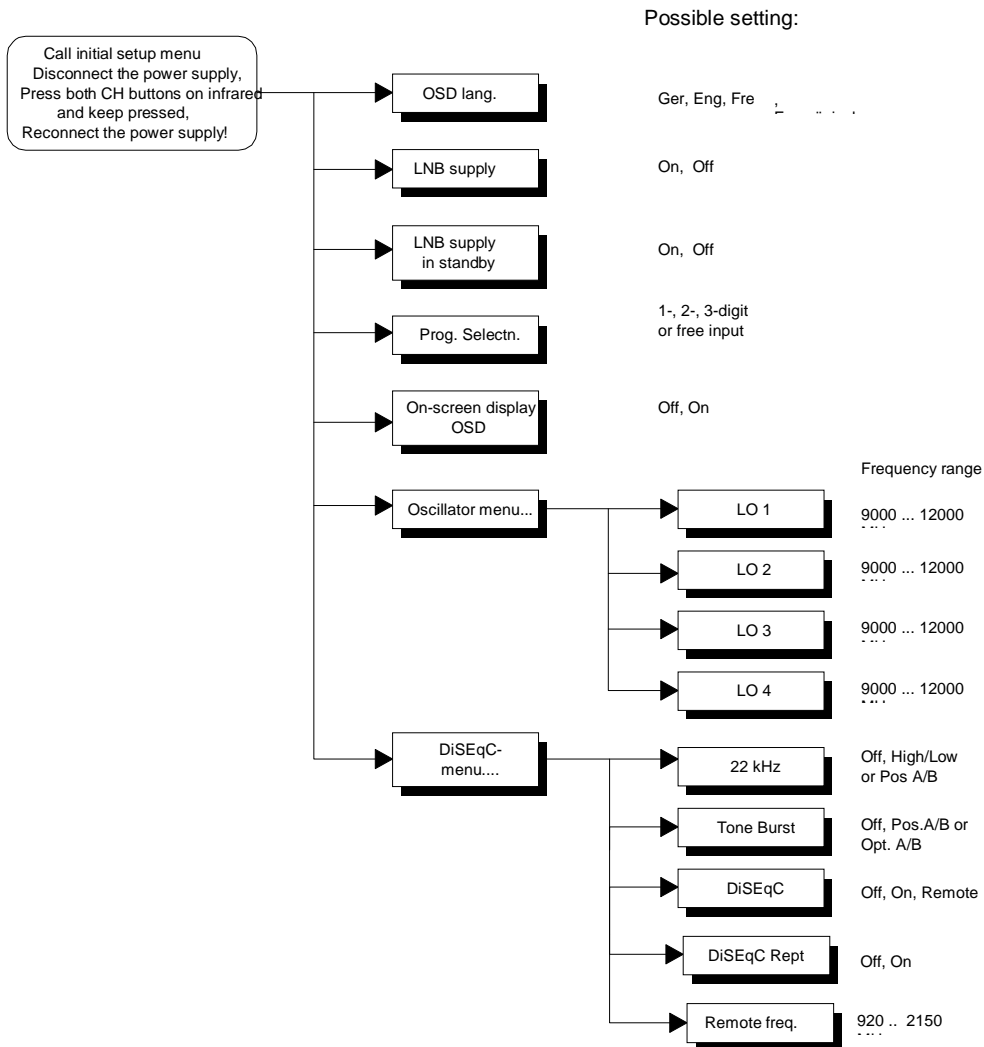

Connection example / Service note

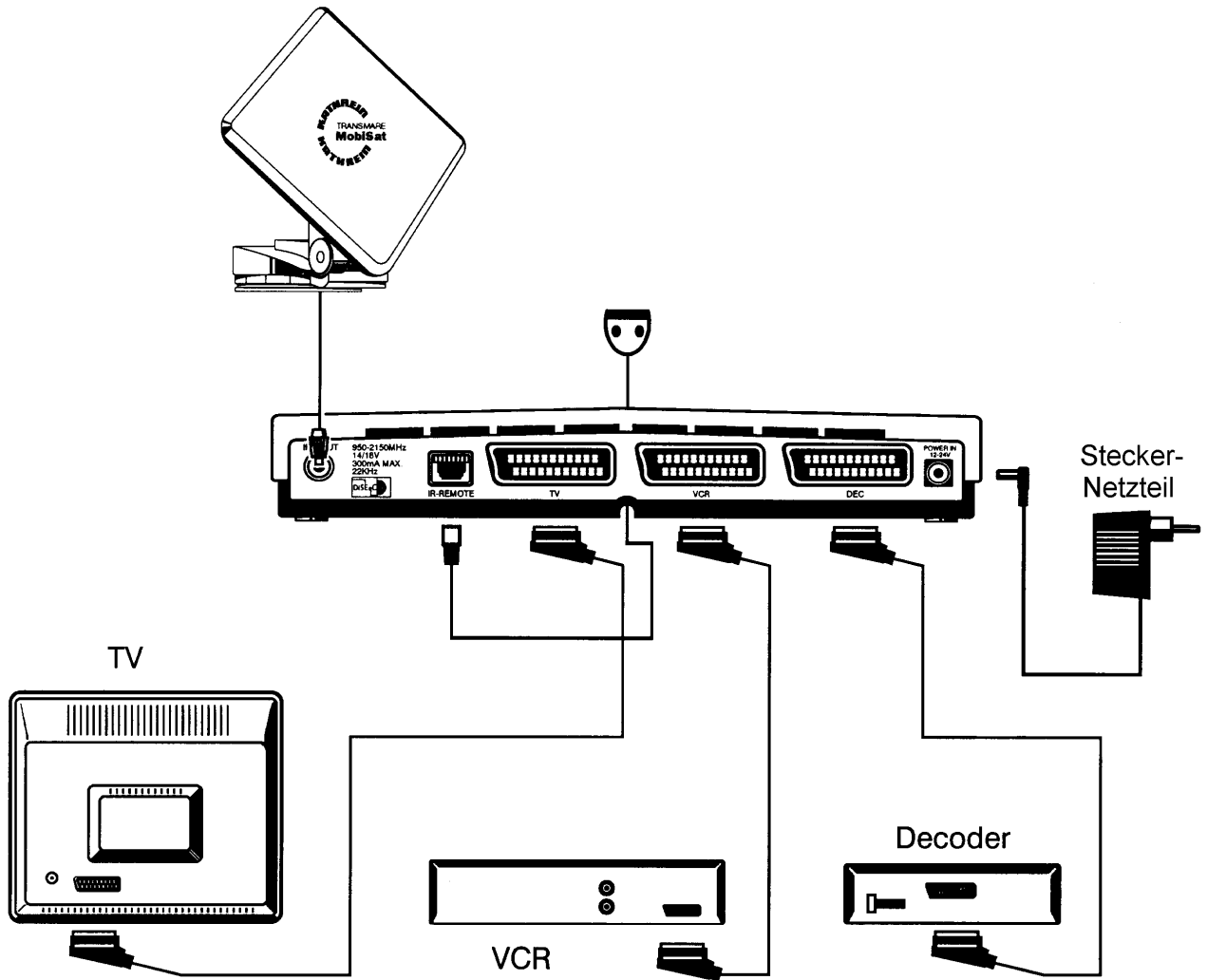

Service note:

Dear Customer,

In the unlikely event that you should experience problems with your receiver, please contact your local specialist dealer or our service organisation.



Cut out here

200

Mounting with cable outlets at the bottom

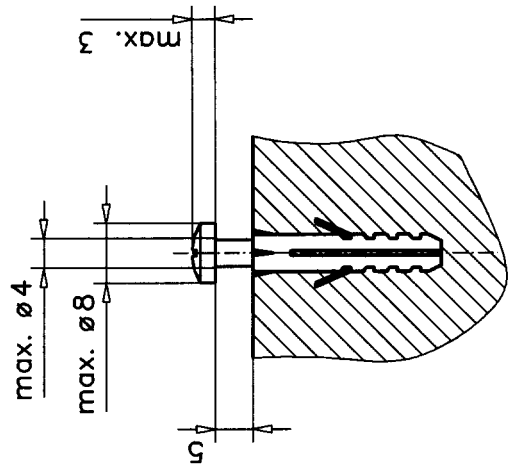
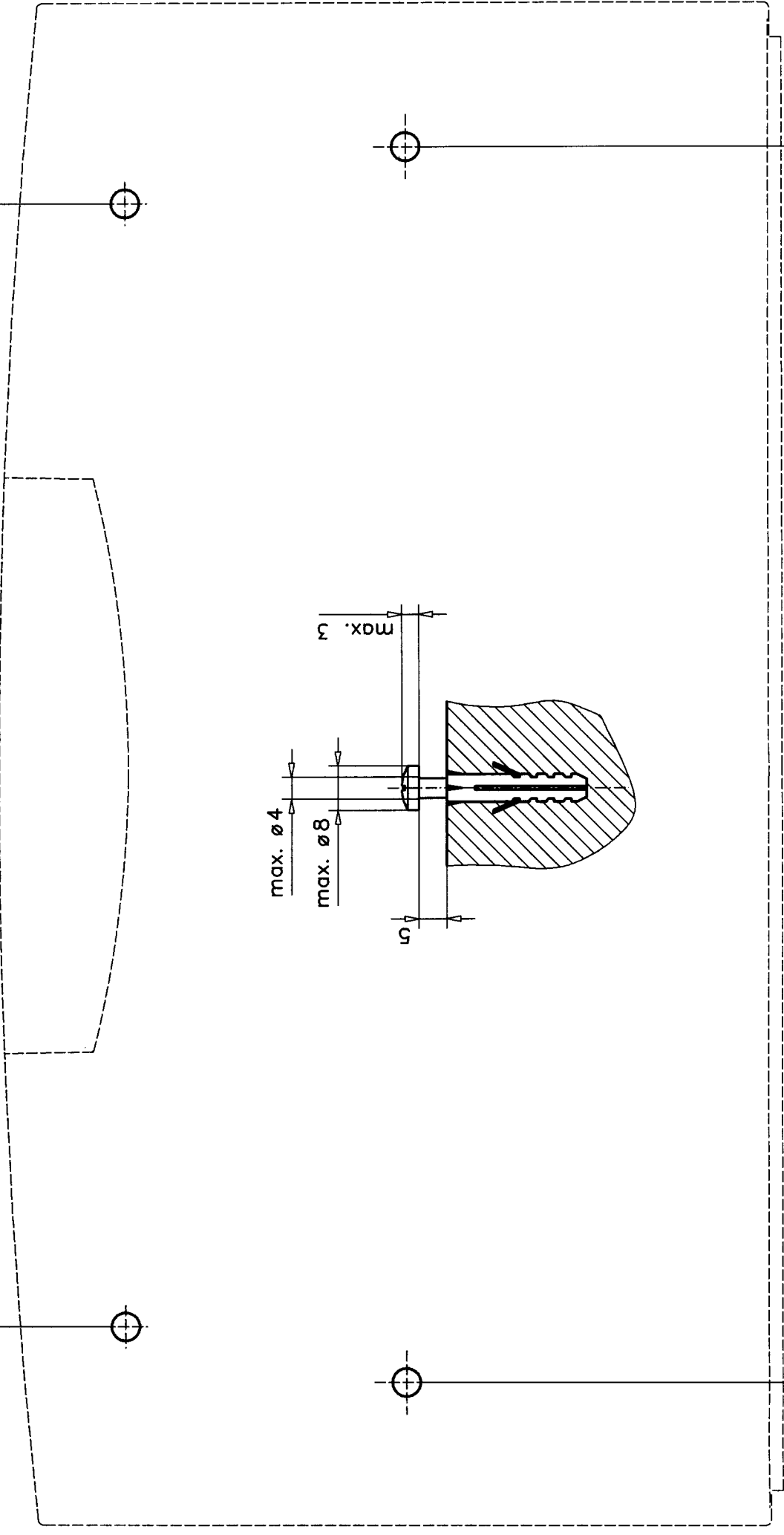

220

Mounting with cable outlets on side

