

Dual-Band Combiner

KATHREIN

Antennen · Electronic

1850 – 1910 / 1930 – 1990 MHz
PCS

1710 – 1755 / 2110 – 2155 MHz
AWS

- Designed for co-siting purposes
- Enables feeder sharing
- Suitable for indoor or outdoor applications
- DC by-pass between all ports
- External DC stop available as an accessory

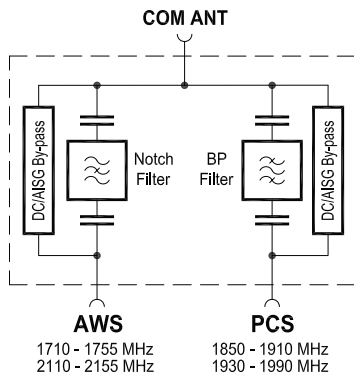
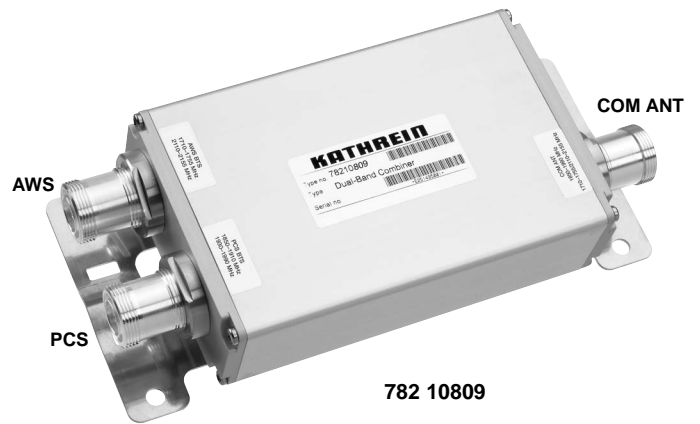

Typical Attenuation Curves

Diagram I

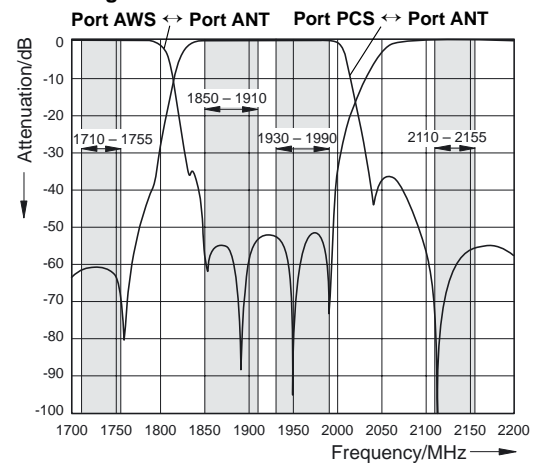
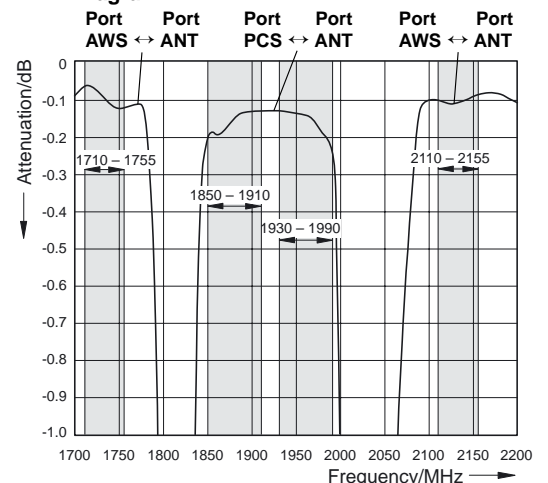

Diagram II



Technical Data

Type No.	782 10809 Single unit	782 10810 Double unit
Pass band PCS AWS	1850 – 1910 (Rx) / 1930 – 1990 (Tx) MHz 1710 – 1755 (Rx) / 2110 – 2155 (Tx) MHz	
Insertion loss Port PCS ↔ Port ANT Port AWS ↔ Port ANT	< 0.3 dB (1850 – 1910 / 1930 – 1990 MHz) < 0.2 dB (1710 – 1755 / 2110 – 2155 MHz)	
Isolation Port PCS ↔ Port AWS	> 50 dB (1850 – 1910 / 1930 – 1990 MHz) > 50 dB (1710 – 1755 / 2110 – 2155 MHz)	
VSWR	< 1.25 (1850 – 1910 / 1930 – 1990 MHz) < 1.25 (1710 – 1755 / 2110 – 2155 MHz)	
Impedance	50 Ω	
Input power Port PCS Port AWS	< 250 W (1850 – 1910 / 1930 – 1990 MHz) < 250 W (1710 – 1755 / 2110 – 2155 MHz)	
Intermodulation products	< -160 dBc (3 rd order; with 2 x 20 W)	
Lightning protection	3 kA, 10/350 μs pulse	
Temperature range	-40 ... +65 °C	
Connectors	7-16 female (long neck)	
Application	Indoor or outdoor (IP 66)	
DC/AISG transparency	By-pass between all ports (max. 2500 mA)	
Weight	2.5 kg	5 kg
Dimensions (w x h x d)	122 x 296 x 64 mm	122 x 296 x 120 mm (including mounting brackets)

936.3344 Subject to alteration.

Dual-Band Combiner

KATHREIN

Antennen · Electronic

1850 – 1910 / 1930 – 1990 MHz
PCS

1710 – 1755 / 2110 – 2155 MHz
AWS

Accessories (order separately)

Type No.	Clamp set suitable for mast diameter of
734 360	34 – 60 mm
734 361	60 – 80 mm
734 362	80 – 100 mm
734 363	100 – 120 mm
734 364	120 – 140 mm
734 365	45 – 125 mm

Type No.	Description
793 301	DC stop

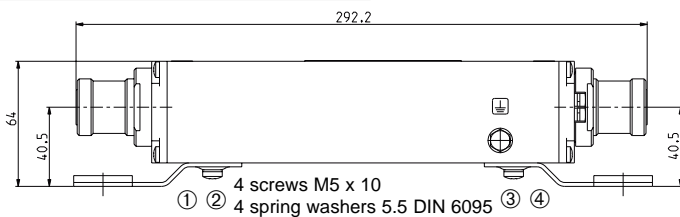

Side view
782 10809
Single Unit

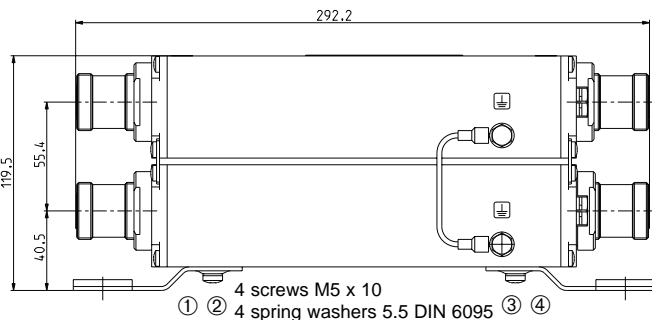

Side view
782 10810
Double Unit

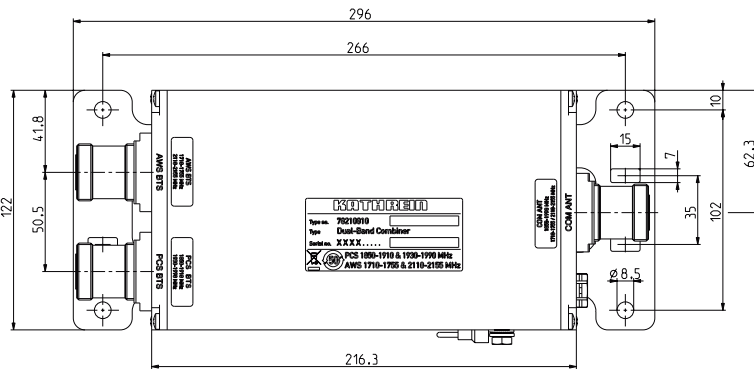

Top view
782 10809 Single Unit,
782 10810 Double Unit

Please note:

The mounting plates can be removed by loosening the screws ① to ④ (M5 x 10) and replaced with other means of mounting, always provided that the max. drilled depth of 8.5 mm is respected with the choice of replacement screws.

As a result of more stringent legal regulations and judgements regarding product liability, we are obliged to point out certain risks that may arise when products are used under extraordinary operating conditions.

Extraordinary operating conditions, such as heavy icing or exceptional dynamic stress (e.g. strain caused by oscillating support structures), may result in the breakage of a mast mounted device or even cause it to fall to the ground.

These facts must be considered during the site planning process.

The Dual-band Combiners are designed to operate under the environmental conditions as described in ETS 300 019-1-4 class 4.1 E and have passed environmental tests as recommended in ETS 300 019-2-4.

The installation team must be properly qualified and also be familiar with the relevant national safety regulations.

The details given in our data sheets have to be followed carefully when installing the antennas, filters, combiners, amplifiers and accessories.

The limits for the coupling torque of RF connectors, recommended by the connector manufacturers must be obeyed.

Any previous datasheet issues have now become invalid.



Dual-Band Combiner

KATHREIN

Antennen · Electronic

1850 – 1910 / 1930 – 1990 MHz
PCS

1710 – 1755 / 2110 – 2155 MHz
AWS

Accessories (order separately)

Type No.	Clamp set suitable for mast diameter of
734 360	34 – 60 mm
734 361	60 – 80 mm
734 362	80 – 100 mm
734 363	100 – 120 mm
734 364	120 – 140 mm
734 365	45 – 125 mm



Type No.	Description
793 301	DC stop

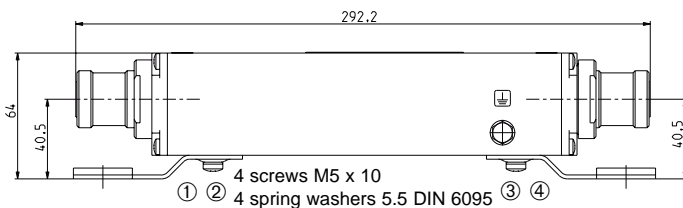

Side view
782 10809
Single Unit

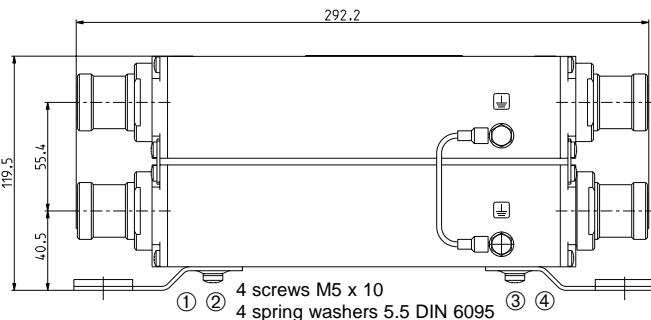

Side view
782 10810
Double Unit

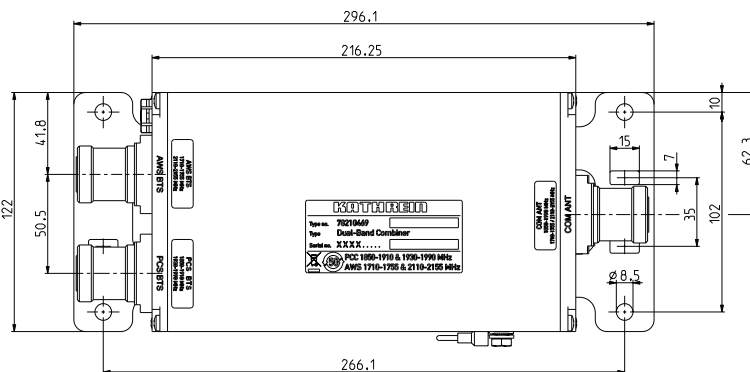

Top view
782 10809 Single Unit,
782 10810 Double Unit

Please note:

The mounting plates can be removed by loosening the screws ① to ④ (M5 x 10) and replaced with other means of mounting, always provided that the max. drilled depth of 8.5 mm is respected with the choice of replacement screws.

As a result of more stringent legal regulations and judgements regarding product liability, we are obliged to point out certain risks that may arise when products are used under extraordinary operating conditions.

Extraordinary operating conditions, such as heavy icing or exceptional dynamic stress (e.g. strain caused by oscillating support structures), may result in the breakage of a mast mounted device or even cause it to fall to the ground.

These facts must be considered during the site planning process.

The Dual-band Combiners are designed to operate under the environmental conditions as described in ETS 300 019-1-4 class 4.1 E and have passed environmental tests as recommended in ETS 300 019-2-4.

The installation team must be properly qualified and also be familiar with the relevant national safety regulations.

The details given in our data sheets have to be followed carefully when installing the antennas, filters, combiners, amplifiers and accessories.

The limits for the coupling torque of RF connectors, recommended by the connector manufacturers must be obeyed.

Any previous datasheet issues have now become invalid.

