

DTMA-UMTS-24-AISG-CWA

Fullband Double Dual Duplex Tower Mounted Amplifier (Masthead Amplifier)

KATHREIN

Antennen · Electronic

- Slimline design
- Double unit for easy use with XPol antennas
- Supports CWA, AISG 1.1 and AISG 2.0 (default)
- AISG setting switchable as described on page 2
- CWA and AISG configurations as described on page 2
- Suitable for antenna RET control according to AISG/3GPP standard
- By-pass mode to ensure cell operation in case of DC power down
- Built-in lightning protection

RET = Remote Electrical Tilt
AISG = Antenna Interface Standards Group
CWA = Current Window Alarm



Technical Data

Type No.	782 10613	
	DTMA-UMTS-24-AISG-CWA (24 dB gain)	
Tx Characteristics		
Frequency range	2110 – 2170 MHz	
Insertion loss	< 0.3 dB (typically 0.15 dB)	
Ripple	< 0.1 dB	
Input power (per input)	< 100 W (+50 dBm) CW / < 1.6 kW (+62 dBm) peak	
Intermodulation products in Rx band	< -117 dBm (2 Tx carriers at +43 dBm)	
Return loss	> 18 dB	
Rx Characteristics		
Frequency range	1920 – 1980 MHz	
Loss in by-pass mode	< 2.5 dB (DC OFF)	
Return loss	> 18 dB (DC ON) / > 12 dB (DC OFF)	
Gain	24 ±1.0 dB (+22 ... +28 °C) / 24 ±1.2 dB (-40 ... +65 °C)	
Gain ripple	< ±0.3 dB	
Noise figure *	< 1.4 dB (+22 ... +28 °C)	
Output 1-dB compression point	> 18 dBm	
3 rd order intercept point (OIP3)	> 25 dBm (typically 30 dBm)	
Environmental Characteristics		
Operating temperature range	-40 ... +65 °C	
IP rating	IP67 (see note on page 2)	
MTBF	> 1 000 000 hours (per TMA)	
EMC	According to ETS 300 342-3	
DC and Alarm Characteristics		
	CWA Mode	AISG Mode
DC supply	9 – 15 V	9 – 30 V
Operating current per TMA (without RET)	130 – 340 mA	Nom. 210 mA at 9 V Nom. 70 mA at 30 V
Alarm management	380 – 420 mA	AISG (see note on page 2)
Mechanical Characteristics		
Material	Aluminium housing	
Connectors	RF AISG	
	7-16 female (long neck) 8-pin female, IEC 60130-9 (Pin 3: RS485B, pin 5: RS485A, pin 6: 9 – 30 V DC, pin 7: DC return, other pins: not connected)	
Mounting	Wall mounting: with 4 screws (max. 8 mm diameter) Mast mounting: with additional clamp set	
Weight	3.8 kg	
Packing size	262 x 502 x 214 mm	
Dimensions (w x h x d)	160 x 205 x 63 mm (without connectors, without mounting brackets)	

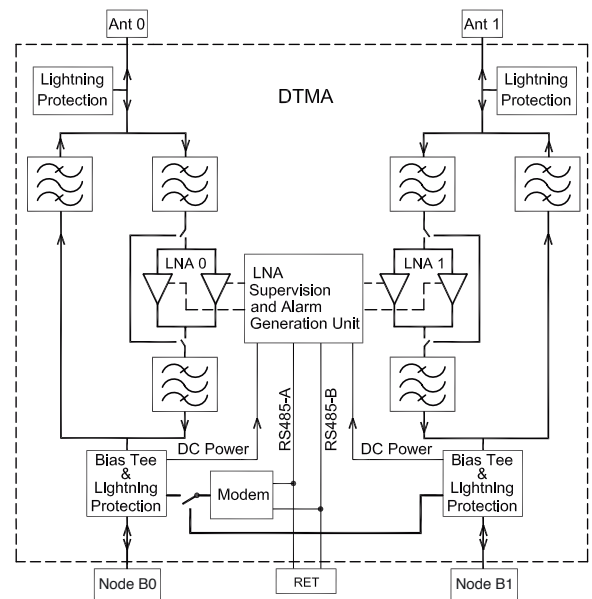

Accessories (order separately)

Type No.	Clamp set suitable for mast diameter of
734 360	34 – 60 mm
734 361	60 – 80 mm
734 362	80 – 100 mm
734 363	100 – 120 mm
734 364	120 – 140 mm
734 365	45 – 125 mm



936.3274/d Subject to alteration.

* Noise figure $\overline{NF} = \frac{NF_{1920\text{ MHz}} + 2 \times NF_{1950\text{ MHz}} + NF_{1980\text{ MHz}}}{4}$
 (Additional variation at -40 ... +60 °C: $\Delta \overline{NF} < 0.4\text{ dB}$)

DTMA-UMTS-24-AISG-CWA

Fullband Double Dual Duplex Tower Mounted Amplifier (Masthead Amplifier)

KATHREIN

Antennen · Electronic

DC Supply, Current Window Alarm and AISG Configuration

(automatically chosen by the DTMA depending on incoming signals)

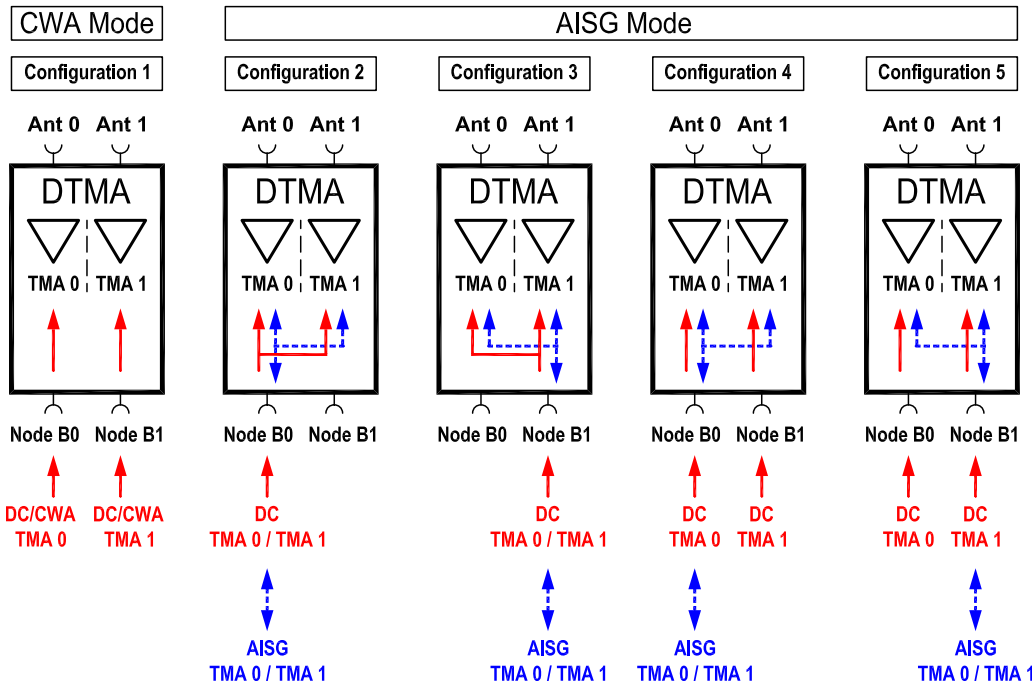

Mounting Instructions

The coupling torque at 7-16 connectors is 25 – 30 Nm!

The tightening torque for fixing the AISG connector must be 0.5 – 1.0 Nm ('hand-tightened').

It is recommended to install the DTMA's with the antenna connectors pointing upwards and the BTS connectors pointing downwards.

In case of DTMA's with RET connectors (Remote Electrical Tilt connectors according to AISG Standard) it is **recommended** to mount the DTMA's in such a way that the RET-connector **always points downwards!** A downward slanted mounting position between the vertical and horizontal plane is also allowed.

AISG Setting

The protocol of the software interface can be switched between AISG 2.0 / 3GPP and AISG 1.1 and vice versa with a vendor specific command (depending on default setting). If the primary station does not support the default setting, it has to be switched over before system start-up. Please contact Kathrein for further information.

Please note

The DTMA is not designed for permanent operation under water. Test conditions for the IP67 rating: submerge depth: 1 m; submerge time 24 hours

As a result of more stringent legal regulations and judgements regarding product liability, we are obliged to point out certain risks that may arise when products are used under extraordinary operating conditions.

Extraordinary operating conditions, such as heavy icing or exceptional dynamic stress (e.g. strain caused by oscillating support structures), may result in the breakage of a mast mounted device or even cause it to fall to the ground.

KATHREIN tower mounted amplifiers are designed to operate under the environmental conditions as described in ETS 300 019-1-4 class 4.1E and have passed environmental tests as specified in ETS 300 019-2-4. The homogenous design of KATHREIN's tower mounted amplifiers use identical modules and materials. Extensive tests have been performed on typical samples and models.

The installation team must be properly qualified and also be familiar with the relevant national safety regulations.



The details given on our data sheets have to be followed carefully when installing the antennas, filters, combiners, amplifiers and accessories.

The limits for the coupling torque of RF connectors, recommended by the connector manufacturers must be obeyed.

Any previous datasheet issues have now become invalid.

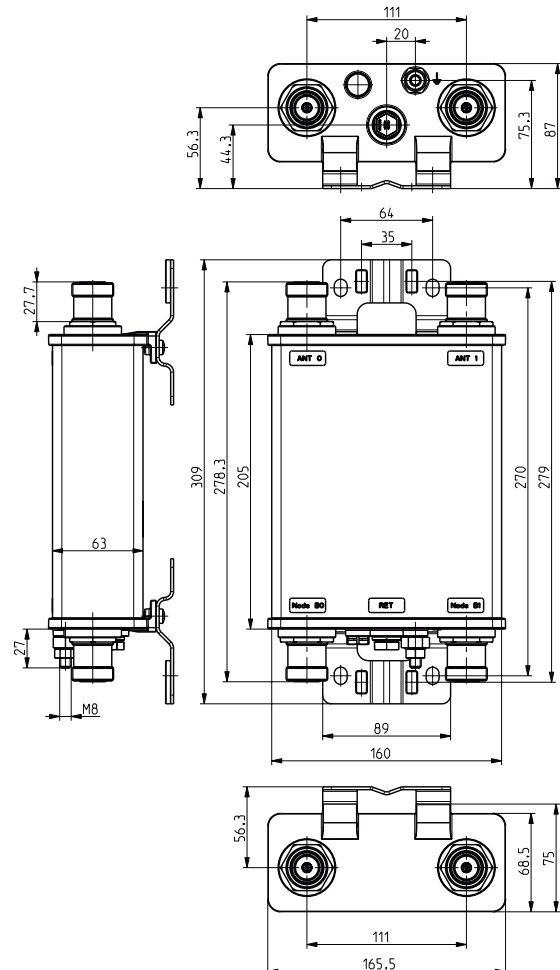

936.3274/d Subject to alteration.