

Bias Tee

800 – 2170 MHz



The Bias Tee is suitable to feed DC voltage and AISG control signals into the feeder cable in order to provide operating voltage and control signals via the RF feeder cable to the TMA or RCU.

- The Bias Tee provides low RF signal insertion loss from the BTS to the antenna port and vice versa.
- The DC voltage and AISG control signal (2.176 MHz) is fed from the DC port to the antenna port while providing a high level of DC isolation from the DC to the BTS port and from the antenna to the BTS port.
- The measures taken in conjunction with the CCU-LOC to protect against static discharge and lightning ensure a high level of reliability and operational safety.

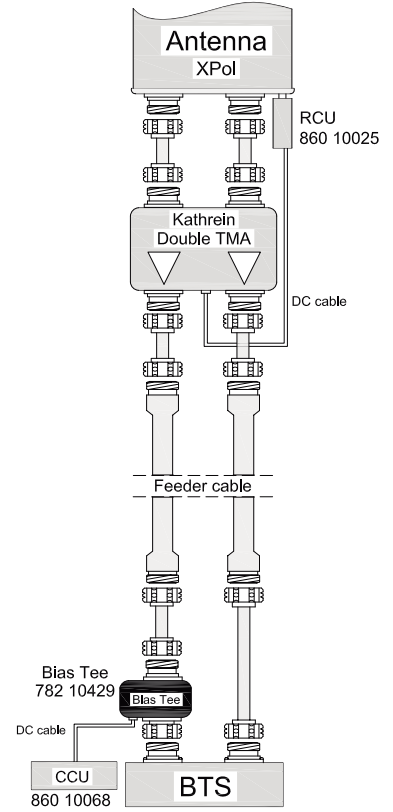
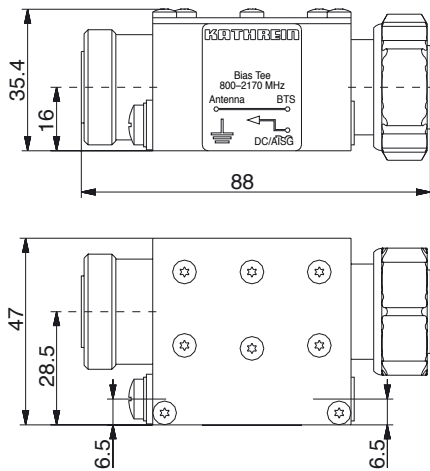

Application Example

Technical Data

Type No.	782 10429
Frequency range	800 – 2170 MHz
Insertion loss BTS ↔ Antenna	< 0.1 dB (800 – 2170 MHz)
Isolation BTS ↔ Antenna BTS ↔ DC/AISG	> 70 dB (DC) > 70 dB (DC)
VSWR	< 1.1 (800 – 2170 MHz)
Impedance	50 Ω
Input power BTS DC/AISG	< 250 W (800 – 2170 MHz) < 1.8 A / 13 VDC < 0.8 A / 29 VDC
Lightning protection	3 kA, 10/350 μs pulse
Intermodulation products	< -160 dBc (3rd order; with 2 x 20 W)
Temperature range	-40 ... +70 °C
Connectors Port 1 BTS Port 2 Antenna Port DC/AISG	7-16 male 7-16 female SMB male
Application	Indoor
Weight	0.6 kg
Packing size	145 mm x 145 mm x 50 mm
Dimensions (w x h x d)	88 mm x 47 mm x 35.4 mm (including connectors and earthing screw of 6 mm diameter)

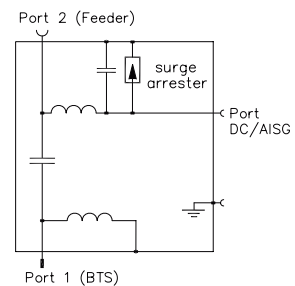

936.2831/a Subject to alteration.